

HS430L

Sodick's high-speed linear machining centre



- 3 Axis Linear Motor Drive
- Spindle temperature controller
- Linear motor temperature controller
- Semi-dry coolant system
- Oil base coolant option
- ATC 16 Tools
- Bed wash down system
- Auto-lubrication system
- Automatic shut down
- Work light
- High speed high accuracy function
- Hard disk 30.0GB
- Macro function
- Programme memory size 30MB
- Ethernet
- Touch Sensor ASSY
 - (BIG, Work piece positioning function)
- Mist collector (AMANO)
- Automatic Tool Length Measuring System
 - BLUM (non contact type)
- Cleaning gun
- Tool tip cleaning system

Technical Specifications

X/Y/Z axis (mm)	420 x 350 x 200
Machine table (W x D, mm)	600 x 400
Maximum load on table (kg)	60
Spindle speed (min ⁻¹)	6000 ~ 40000
Max acceleration X/Y/Z axis (G)	>1
Rapid feed rate (m/min)	36
Maximum tool diameter (mm)	Ø 6
Machine dimensions (W x D x H, mm)	1500 x 1625 x 2105
Machine installation dimensions (W x D, mm)	2200 x 3175
Machine weight (kg)	5800
Tool holder capacity	16

Options

Work piece changer AWC 30/AWC 60
Tool changer ATC 45
Tool holder E25/E32

HS430L

Technical Specifications



Side View

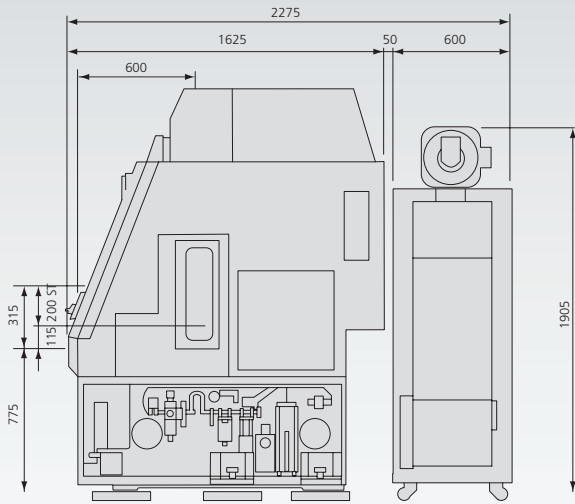

Front View

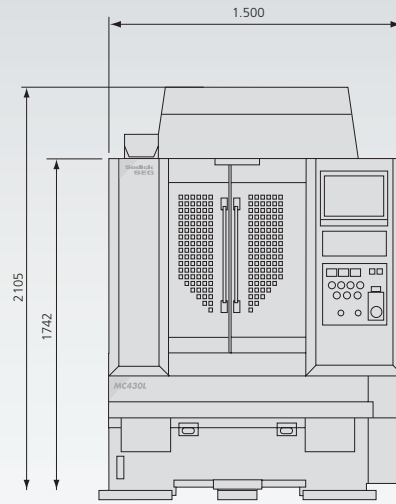

Top View

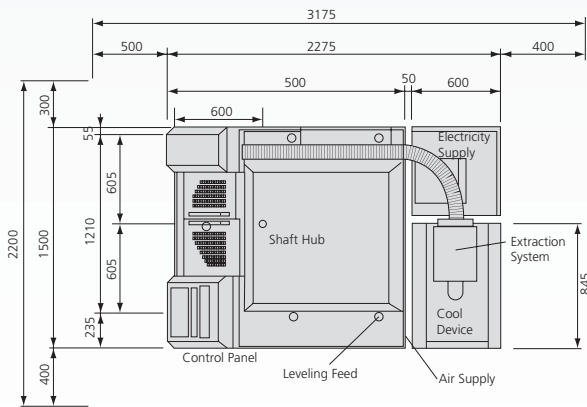

Due to ongoing research, specifications are subject to change without prior notice.

Sodick

create your future

Sodick Europe Ltd.

Rowley Drive, Baginton
Coventry, CV3 4LS
United Kingdom

Phone +44 (0) 24 7621 4314
Fax +44 (0) 24 7630 5680

Sodick Contact

email europa@sodick.eu.com
online www.sodick.org