

Specifications

Technical Specifications	AQ15L	AQ20L
XYZ axis travel (mm)	900 x 1500 (+500) x 600	1200 x 2000 x 600
Table dimensions (mm)	1000 x 2000	1500 x 2000
Worktank dimensions (mm)	1400 x 2590 x 800	1900 x 2590 x 800
Dielectric level (min ~ max, mm)	400 ~ 750	400 ~ 750
Max. workpiece weight (kg)	10,000	10,000
Max. electrode weight (kg)	100	100
Distance from floor to table top (mm)	1000	1000
Machine tool dimensions (W x D x H, mm) (Incl. power supply and dielectric tank)	3050 x 5295 x 4220	3550 x 5785 x 4220
Step resolution (mm)	0.0001	0.0001
Machine weight (kg)	18000	22000
Controlled axis	4	4
Air pressure (Automatic Clamping chuck, MPa)	0.65	0.65

Dielectric Tank	AQ15L	AQ20L
External dimensions (W x D x H, mm)-	3050 x 2050 x 2550	3340 x 2450 x 2550
Empty weight (kg)	2200	3400
Dielectric fluid	Oil	Oil
Capacity (l)	4500	6000
Filtration method	12 Replaceable paper filters (MF-2400)	12 Replaceable paper filters (MF-2400)

The dielectric chillers on Sodick machines contain either fluorinated greenhouse gas R410A or R407C.
Due to ongoing research, specifications are subject to change without prior notice.

Floor Layout

AQ15L

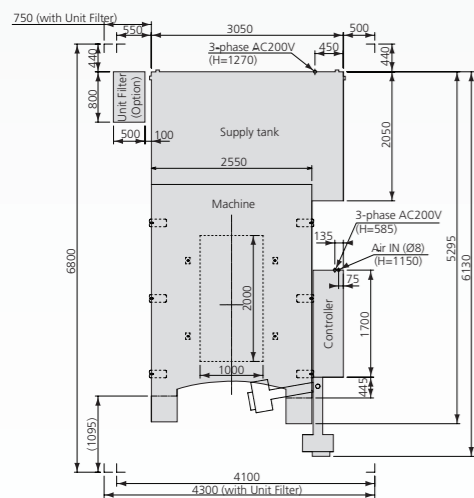

AQ20L

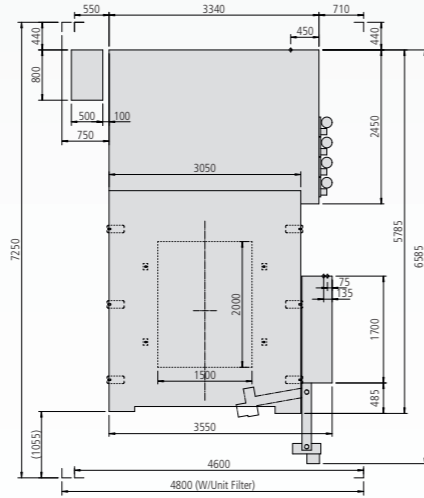

Extra Large Size Linear Die Sinker EDM

AQ15L/AQ20L



create your future

Sodick Europe Ltd.

Agincourt Road
Warwick, CV34 6XZ
United Kingdom

Sodick Contact

Phone +44 (0) 19 2669 8888
email europe@sodick.eu.com
online www.sodick.org



create your future

Core Technology

Five Core Technologies Developed In-House For Achieving The World's Highest Quality Machining

Starting with the development of electrical discharge circuits, Sodick has continued to make untiring efforts in the research and development of advanced EDMs. Sodick's philosophy has been the pursuit of the highest level of accuracy, speed and versatility of machining in order to provide the highest quality products to its customers.

Sodick's: Power Supply Units, Discharge Units, Linear Motors, Motion Controllers and Fine Ceramic Components have evolved as its five core technologies. These developments have positioned Sodick at the pinnacle of EDM technologies.

Tech 1&2

NC Power Supply Unit + Discharge Unit

The Sodick Die Sinker EDM Series features Sodick's latest "LN2 series" power supply unit, which is capable of high-speed, high-precision and high-efficiency machining. The outstanding performance of the LN2 series power supply is controlled by a modern in-house designed NC system running on Windows Operating System. The user interface benefits from a 15" colour touch screen for ease of use and operation.

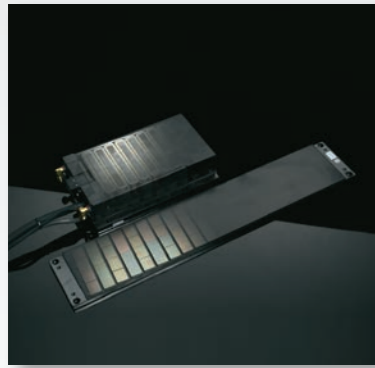
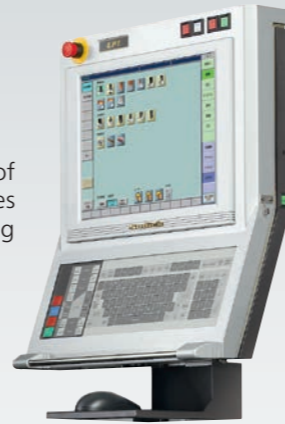

Tech 3

Linear Motor

The most outstanding features of the Sodick in-house developed and manufactured Linear Motors are high-speed axis motion and quick response, which result from wear-free motion and without the need for old-fashioned ball screws. Conventional drive systems use ball screws to convert the rotational motion of the motor into the linear motion of the axis stroke, leading to the unavoidable deterioration in the response of high speed servo motors due to back-lash and mechanical lost motion. However linear motors directly provide motion to each axis without converting rotational motion of motor to linear movements.

Tech 4

Motion Controller

In order to achieve maximum performance with a linear motor, the K-SMC motor controller is also developed in-house and incorporates Sodick control know-how accumulated over the years.

The feedback from the spark gap is directly input in to the K-SMC board allowing for instantaneous adaptation of the sparking conditions.

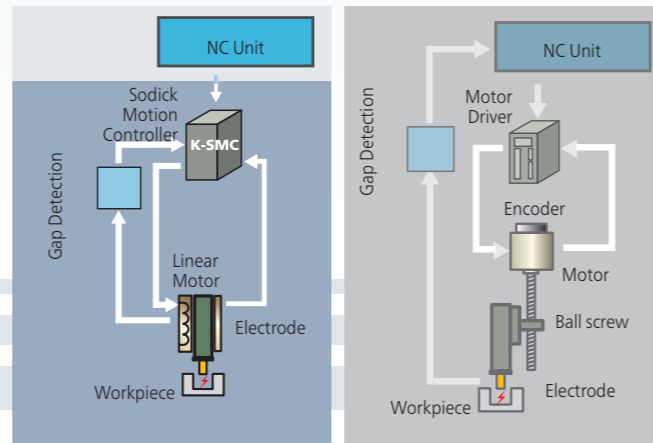

Linear Motor Drive

Conventional Ball Screw

Tech 5

Ceramic Components

In critical components, the Sodick Die Sinker EDM series is equipped with in-house made ceramic material, which has been carefully researched and is considered as the best material for use in high-end EDM machines.



Advanced Machine Design with Twin Linear Motors

Machine's improved Y axis design now features twin linear motor drive and twin linear scale system to ensure synchronised movement.

Twin Linear Motor and twin linear scales on Y Axis



Rigid Cast Construction and Gantry Structure

The machine cast construction is designed with heavily ribbed sections to provide superior long term rigidity and stability. The surfaces to which the THK Ball-Type Linear Guideways, are mounted on scraped by hand surfaces to ensure a perfectly flat surface and outstanding machine geometry.

Work-tank unit is independently located within the gantry structure. Thanks to its advanced machine design of free-standing X and Y-axis gantry structure eliminates deformation from work-piece loads and allows accurate positioning of the Z axis over the work-piece.

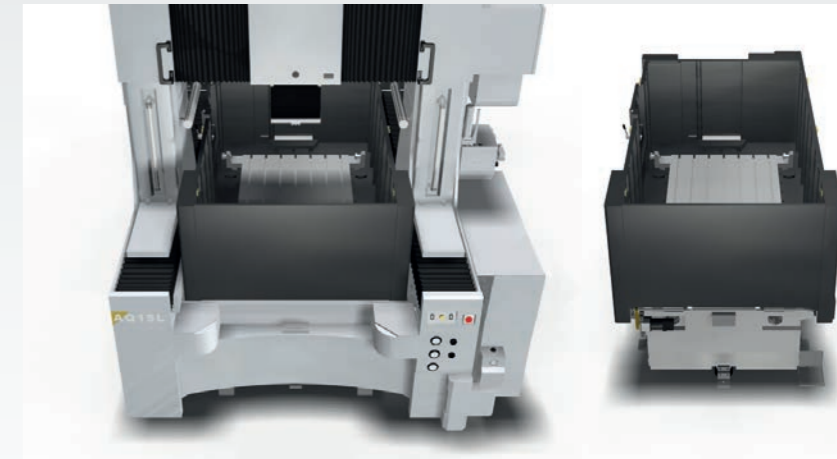

ATC Unit (Optional)

The Automatic Tool Changer (ATC) unit, which is available as an option on AQ large EDM series, allows unattended machine operation. With the LN Professional, operators can easily program the automatic operation with use of ATC. 3 different sizes of ATC are available; 8, 16 or 32 stations. (Images show 8-station Shuttle ATC)

High Precision Rotary Head, C Axis (Optional)

The Sodick Rotary Head (C axis) "SEC10" offers 1/1,000,000 of standard resolution. It enables high precision indexing with direct-drive and continuous rotation (20rpm), expanding the machining capabilities.

	SEC-10
Resolution	1/1,000,000
Max. spindle speed	2 - 20 rpm
Max. current	80 A
Flushing through Axis	as standard

