

K3BL



High-speed hole EDM by Sodick for micro-holes of 0.08 mm diameter

- Linear motor (Z axis)
- CNC control LN10K with SMC (Sodick Motion Control)
- LN assist software for optimum condition search
- Automatic depth measurement
- Improved ease of operation
- Guide set 0.155 mm
- Electrode tube each 0.15 mm
- Electro-discharge machine
- Splash guard
- Workpiece fixtures
- LAN

Technical Specifications

X/Y/Z axis travel (mm)	300 x 200 x 300
W-Axis (Cutting axis in mm)	250
Table dimensions (mm)	600 x 300
Max. workpiece dimensions (mm)	600 x 300 x 160
Max. workpiece weight (kg)	300
Electrode diameter (mm)	0.08 ~ 3.0
Electrode guide to table surface (mm)	60 ~ 310
Machine tool dimensions (W x D x H, mm)	1130 x 1645 x 2360
Machine tool weight (kg)	1500

Dielectric tank

External dimensions (W x D x H, mm)	1140 x 600 x 1000
Dielectric fluid	Oil
Capacity (l)	245
Filtration method	Replaceable paper filter (MF-2400)

Options

Remote controller	Electrode holder stand
Oscilloscope	Flush block
MCP circuit (for hard metal drilling)	Electrode holder set
18-position ATC (Automatic tool changer)	TS-B guide set
15-position ATC with AEF (Automatic electrode feeder)	



K3BL

Side View

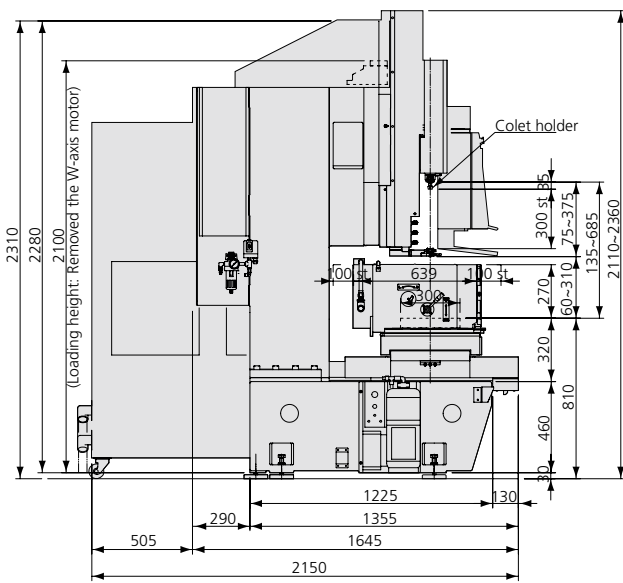

Front View

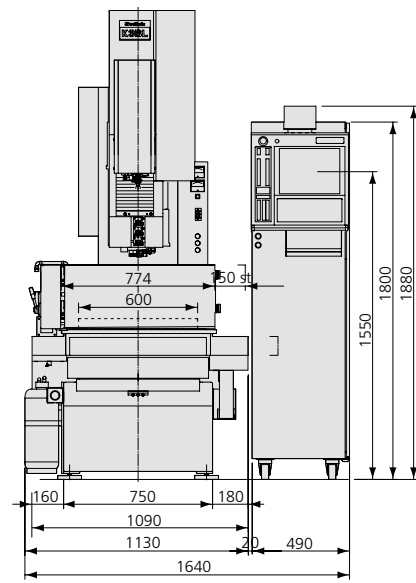

Top View

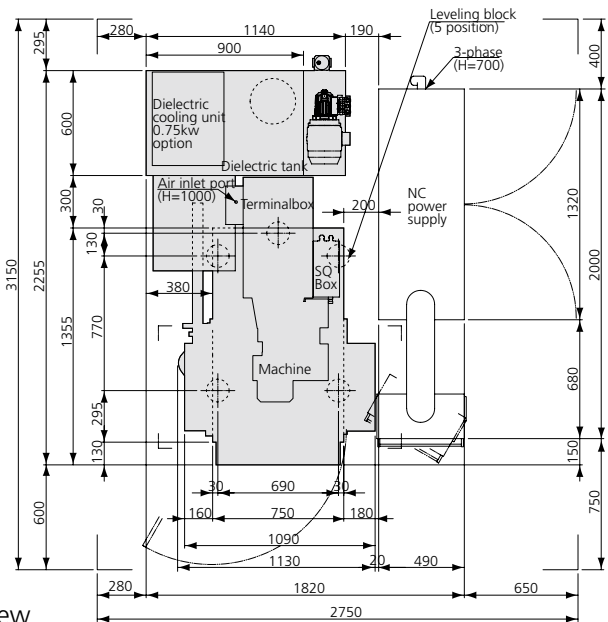

Sodick

create your future

Sodick Europe Ltd.

Rowley Drive, Baginton
Coventry, CV3 4LS
United Kingdom

Phone +44 (0) 24 7621 4314
Fax +44 (0) 24 7630 5680

Sodick Contact

email europa@sodick.eu.com
online www.sodick.org