

HS650L



Super High-accuracy milling machine

- 3 Axis Linear Motor Drive
- Spindle Temperature Controller
- Linear Motor Temperature Controller
- Semi-Dry Coolant System
- Oil Base Coolant Option
- ATC 16 Tools
- Bed Wash Down System
- Auto-Lubrication System
- Automatic Shut Down
- Work Light
- Hard Disk 30.0GB
- High Speed High Accuracy Function (SEPT II – Sodick Enhanced Precision Technology)
- Macro Function
- Programme Memory Size 30MB
- Lan interface
- Touch Sensor ASSY (BIG, Work piece positioning function)
- Mist Collector (AMANO)
- Automatic Tool Length Measuring System – BLUM (non contact type)
- Cleaning Gun
- Tool Tip Cleaning System

Technical specifications

X/Y/Z axis (mm)	620 x 500 x 300
Machine table (W x D, mm)	750 x 500
Maximum load on table (kg)	120
Spindle speed (min ⁻¹)	6000 ~ 40000
Max acceleration X/Y/Z axis (G)	>1
Rapid feed rate (m/min)	36
Maximum tool diameter (mm)	ø 6
Machine dimensions (W x D x H, mm)	1825 x 2956 x 2540
Machine installation dimensions (W x D, mm)	3050 x 4300
Machine weight (kg)	7200
Tool holder capacity	16

Options

- Work piece changer AWC 30/AWC 60
- Tool changer ATC 45
- Tool holder E32



Side View

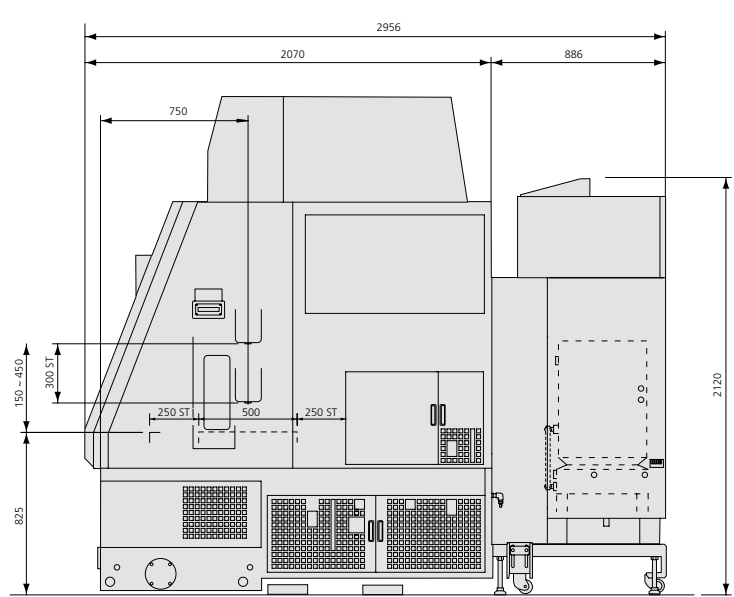

Front View

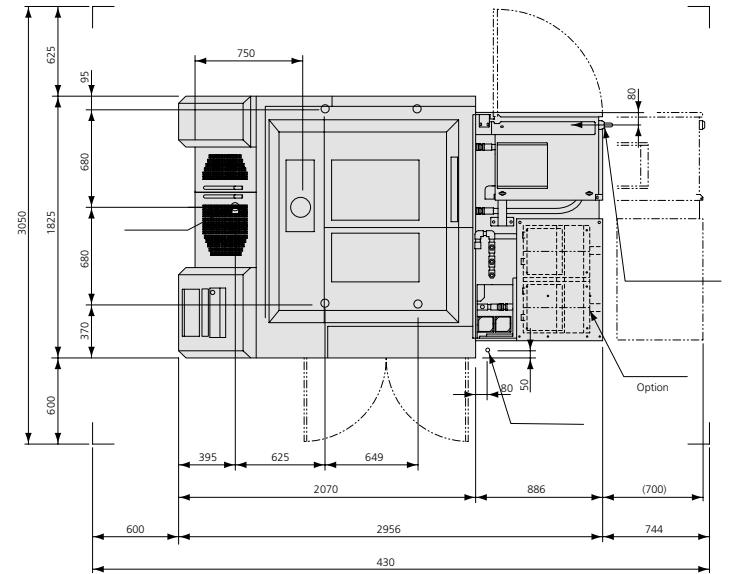
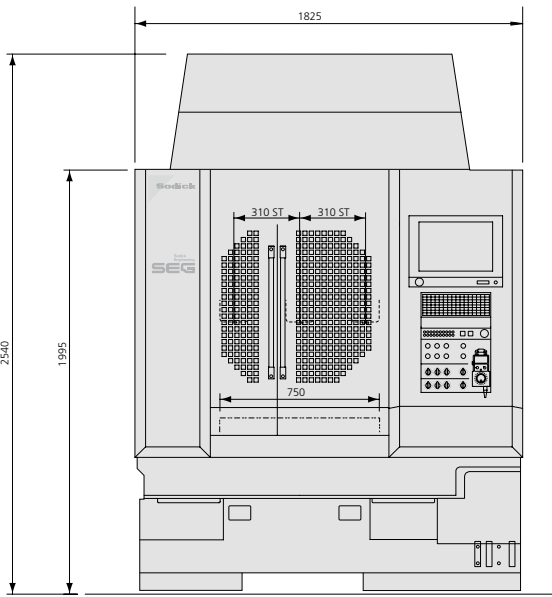

Top View

Sodick

create your future

Sodick Hightech Europe Ltd.
 Rowley Drive, Baginton
 Coventry, CV3 4FG
 United Kingdom

Phone +44 (0) 24 7651 1444
 Fax +44 (0) 24 7651 1488

Sodick Contact
 online www.sodick.org