

AQ327L Premium



The next technological step in linear wire EDM

- 10 year warranty on positioning accuracy
- Linear motor (X, Y, U, V axis)
- Linear glass scales (X, Y, U, V axis)
- Ceramic components
- Linear motor cooling unit
- LP33W high speed generator
- Intelligent Q³vic EDW
- Esprit CAM software offline*
- Remote controller
- 3-sided rise and fall work tank
- Improved ease of operation
- High speed electrolysis free circuit
- SODICK Fine Corner Control
- Energy saving circuit
- Super PIKA finishing circuit
- FTII (Fine pick-up function)
- Automatic water level control
- Super jet AWT (Automatic wire threader)
- Wire end remover
- Dielectric cooling unit
- Active Power Restart (UPS)
- Voltage stabiliser
- LAN interface
- 15" TFT screen
- USB Port
- Totalising hour metre
- Work light

Technical Specifications

Max. workpiece weight (kg)	500
Max. workpiece dimensions (W x D x H, mm)	570 x 420 x 240
X/Y/Z axis travel (mm)	370 x 270 x 250
U/V axis travel	120 x 120
Taper angel	±25°
Wire diameter (mm)	ø 0.15 ~ ø 0.33
Wire tension (N)	3 ~ 23
Max. wire speed (mm/s)	420
Distance from floor to table top (mm)	995
Controlled axis	5
Machine tool dimensions (W x D x H, mm)	2225 x 2395 x 2220
Machine installation dimensions (mm)	3200 x 3200
Machine weight (kg)	3950

Options

Jumbo feeder	Wire chopper
0.1mm wire spec.	Oscilloscope
Taper flex 45 (for taper cutting up to 45°)	Automation System: work piece changer, electrode changer and robots
JauchSchmider Rotary table (indexing or simultaneous movement)	Custom colour
WS4P/5P rotary table (indexing or simultaneous movement)	Left handed CNC specification (Factory option)

* regional option



Side View

Front View

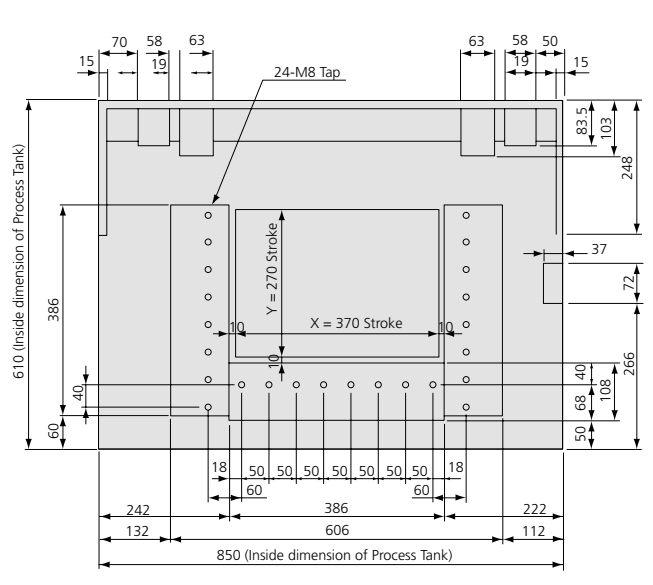
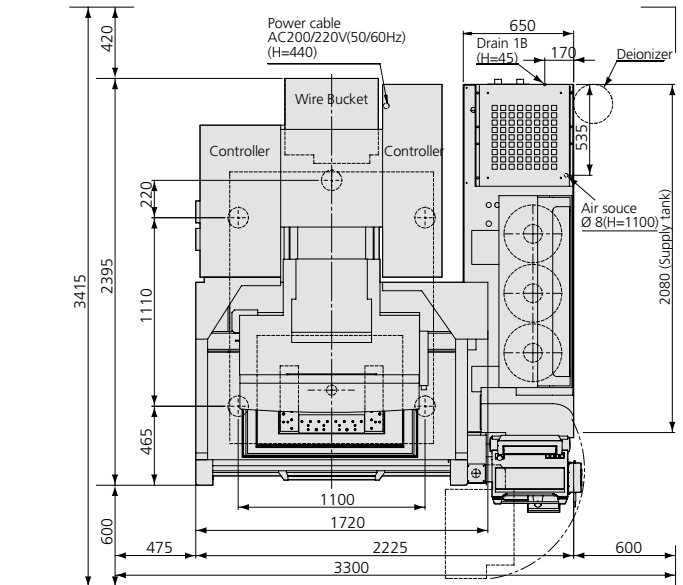
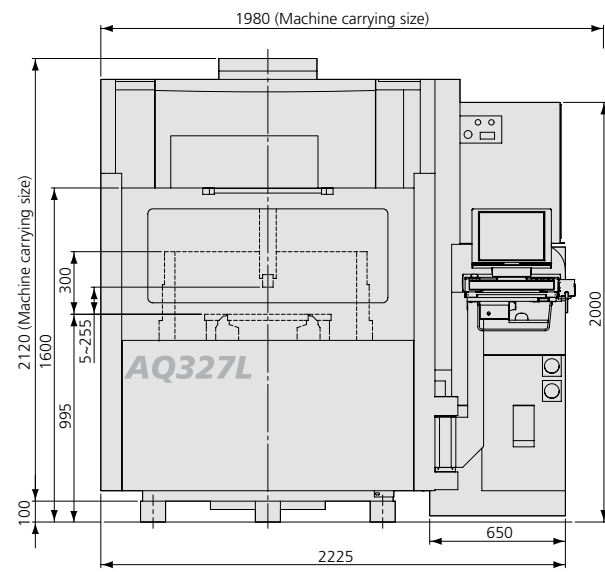
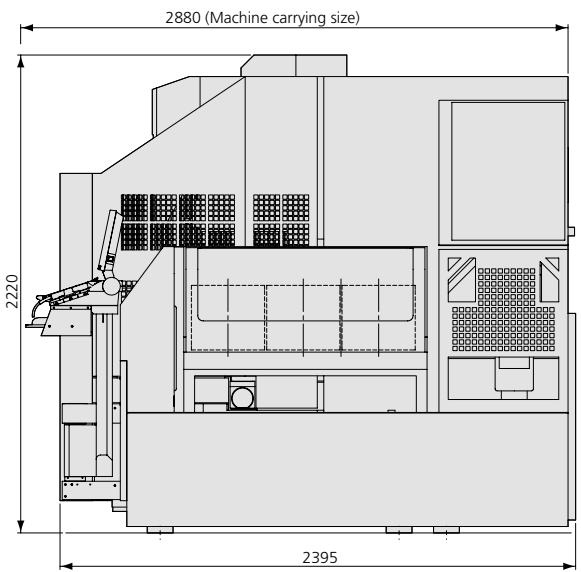

Top View

Work Table

Sodick

create your future

Sodick Europe Ltd.
Rowley Drive, Baginton
Coventry, CV3 4LS
United Kingdom

Phone +44 (0) 24 7621 4314
Fax +44 (0) 24 7630 5680

Sodick Contact

email europe@sodick.eu.com
online www.sodick.org