

AG400L



The 5th Generation Linear EDM

- 10 year warranty on positioning accuracy
- Linear motor (X, Y, U, V axis)
- Absolute linear scales (X, Y, U, V axis)
- Ceramic components
- Linear motor cooling unit
- Remote controller
- 3-sided rise and fall work tank
- Improved ease of operation
- High speed electrolysis free circuit
- SODICK Fine Corner Control
- Energy saving circuit
- FTII (Fine pick-up function)
- Automatic water level control
- Super jet AWT (Automatic wire threader)
- Wire end remover
- Dielectric cooling unit
- Voltage stabiliser
- LAN interface
- 15" TFT screen
- USB port
- Work light

Technical Specifications

Max. workpiece weight (kg)	500
Max. workpiece dimensions (W x D x H, mm)	600 x 470 x 240
X/Y/Z axis travel (mm)	400 x 300 x 250
U/V axis travel	120 x 120
Taper angle at 120 mm height	±25° (±45°: option)
Wire diameter (mm)	∅ 0.1 ~ 0.3
Wire tension (N)	3 ~ 23
Max. wire speed (mm/s)	420
Distance from floor to table top (mm)	995
Controlled axis	5
Machine tool dimensions (W x D x H, mm)	2240 x 2395 x 2220
Machine installation dimensions (mm)	3300 x 3400
Machine weight (kg)	3950

Options

Jumbo feeder	0.07 / 0.05 mm wire spec (Factory option)
HTP high voltage circuit	Oscilloscope
Taper flex 45 (for taper cutting up to 45°)	Automation System: work piece changer, electrode changer and robots
L-Cut (Wire chopper)	Custom colour
Esprit CAM software offline	8-axis simultaneous control (Factory option)
WS4P/5P rotary table (indexing or simultaneous movement)	Left handed CNC specification (Factory option)

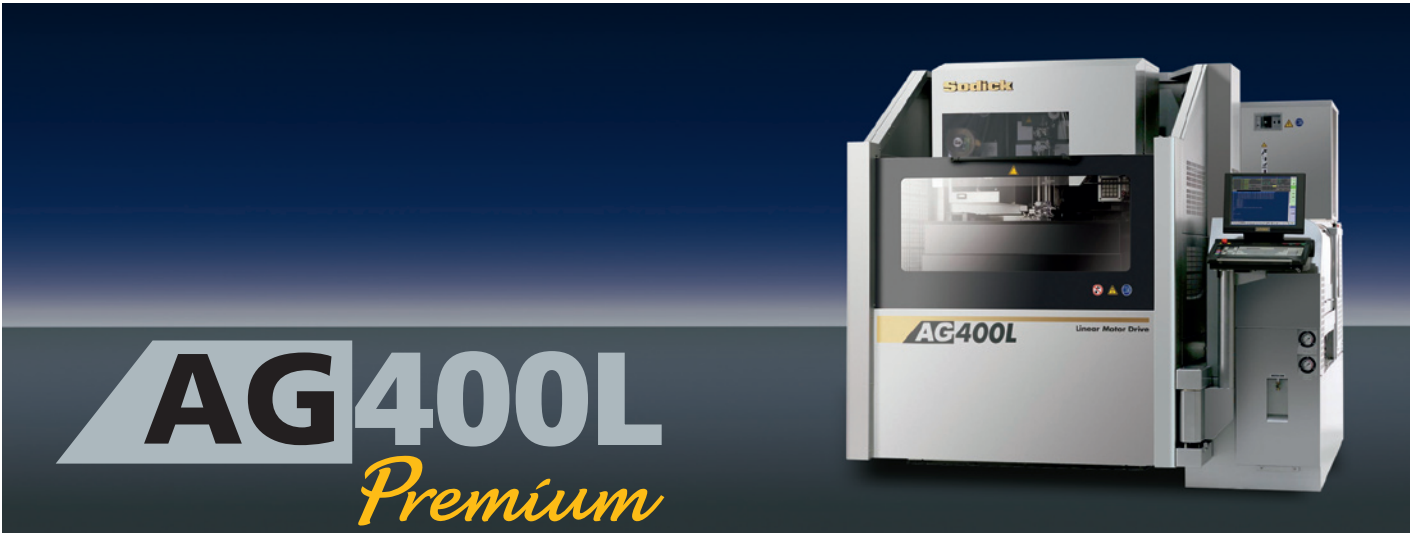

Side View

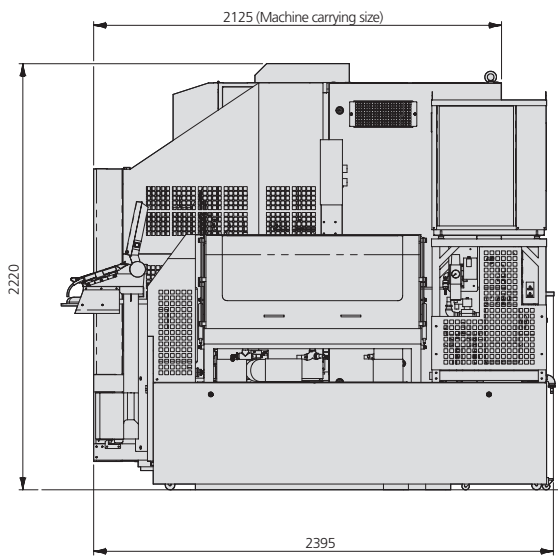

Front View

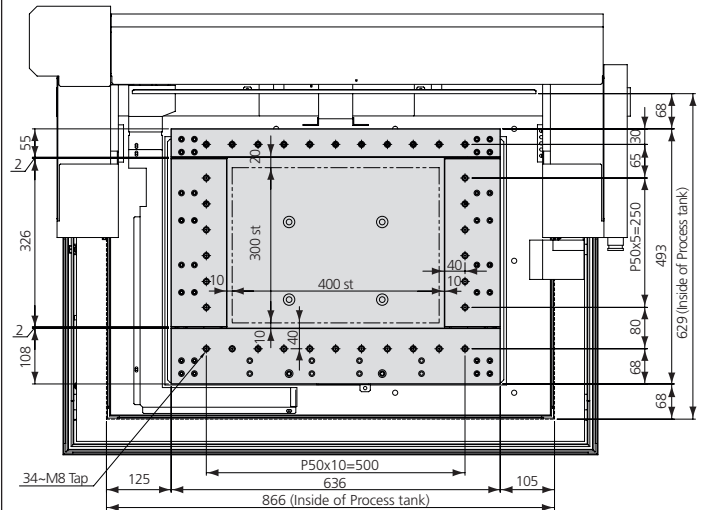
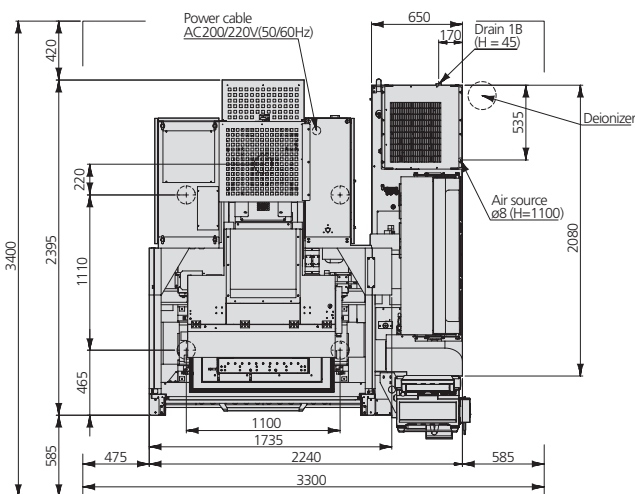
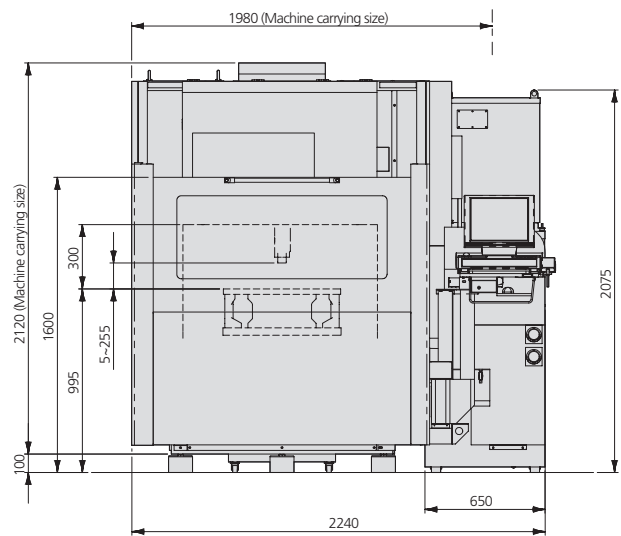

Top View

- All CE spec machines have external transformer with dimension of ca. 650 x 460 x 540mm

Work Table

Sodick

create your future

Sodick Europe Ltd.

Rowley Drive, Baginton
Coventry, CV3 4FG
United Kingdom

Phone +44 (0) 24 7621 4314
Fax +44 (0) 24 7630 5680

Sodick Contact

email europe@sodick.eu.com
online www.sodick.org